

UNIT, DIRECT SUPPORT, AND GENERAL SUPPORT MAINTENANCE
REPAIR PARTS AND SPECIAL TOOLS LIST
TRUCK, 5-TON, 6X6, M809 SERIES TRUCKS (DIESEL)

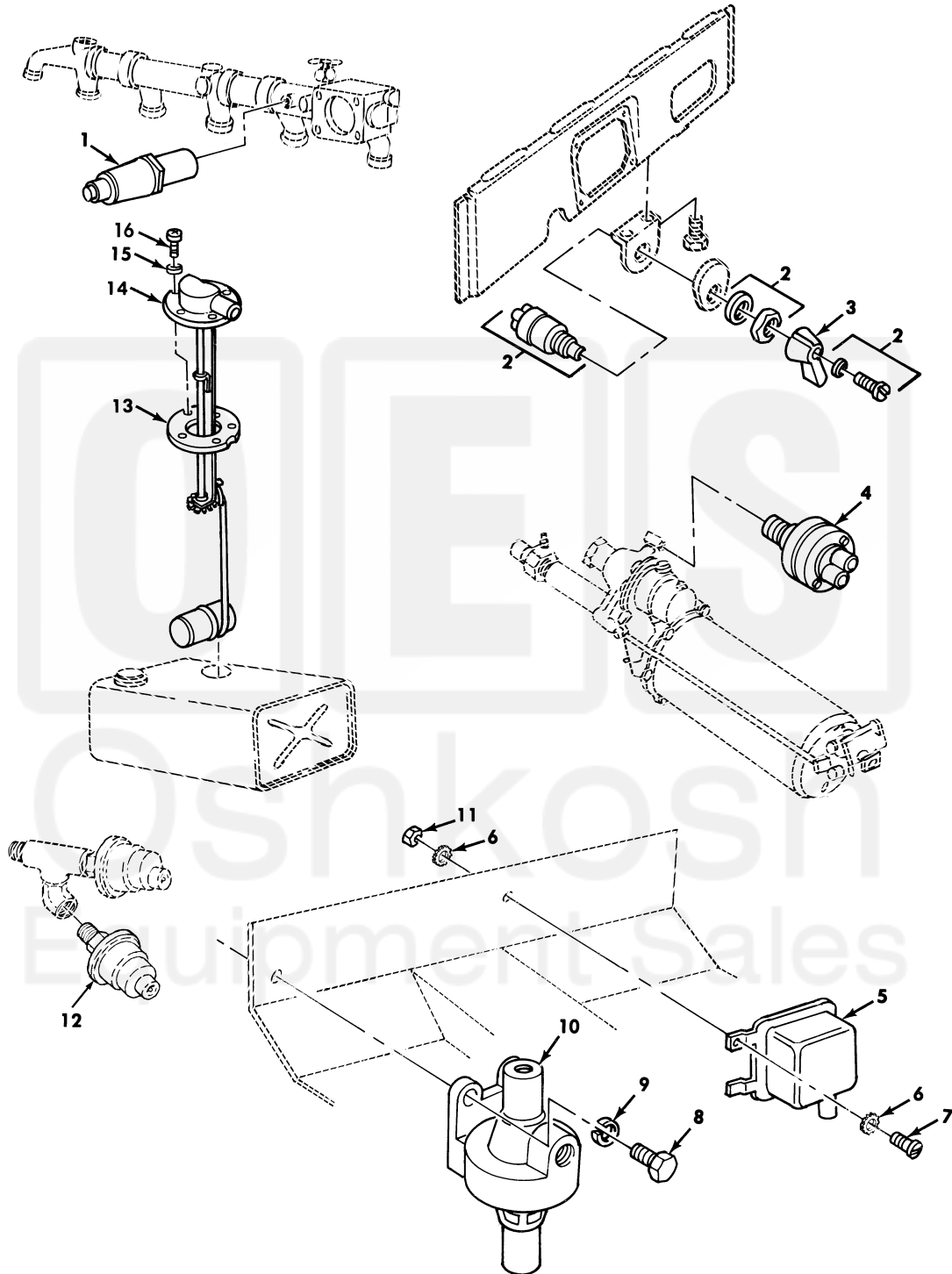

Figure 109. Temperature Transmitter, Warning Light, Pressure Switches, Low Air Pressure Buzzer, and Fuel Level Transmitter.

(1) ITEM NO	(2) SMR CODE	(3) NSN	(4) CAGEC	(5) PART NUMBER	(6) DESCRIPTION AND USABLE ON CODE (UOC)	(7) QTY
GROUP 0610 SENDING UNITS AND WARNING SWITCHES						
FIG. 109 TEMPERATURE TRANSMITTER, WARNING LIGHT, PRESSURE SWITCHES, LOW AIR PRESSURE BUZZER, AND FUEL LEVEL TRANSMITTER						
1	PAOZZ	6685-00-042-4165	15434	142511	TRANSMITTER, TEMPERA.....	1
2	PAOZZ	5930-00-699-9438	81349	MIL-S-13623/1-2	SWITCH, ROTARY.....	1
3	PAOZZ	5930-00-130-5349	19207	5381088	HANDLE, SWITCH.....	1
4	PAOZZ	2540-00-789-6192	19207	11602160	SWITCH, PRESSURE STOP LIGHT.....	1
5	PAOZZ	6350-00-772-7664	19207	8675930	BUZZER.....	1
6	PAOZZ	5310-00-889-2528	96906	MS45904-68	WASHER, LOCK.....	6
7	PAOZZ	5305-00-042-5581	21450	425581	SCREW, ASSEMBLED WAS.....	3
8	PAOZZ	5305-00-068-0502	96906	MS90725-6	SCREW, CAP, HEXAGON H.....	2
9	PAOZZ	5310-00-582-5965	96906	MS35338-44	WASHER, LOCK.....	2
10	PAOZZ	5930-00-058-1576	96906	MS27152-1	SWITCH, PRESSURE.....	1
11	PAOZZ	5310-00-061-7325	96906	MS21045-4	NUT, SLFLKG HEXAGON.....	3
12	PAFZZ	6620-00-993-5546	19207	7416363	TRANSMITTER, PRESSUR.....	1
13	PAOZZ	5330-00-753-9072	19207	7539072	GASKET.....	1
14	PAOZZ	6680-00-226-4574	96906	MS500040-6	TRANSMITTER, LIQUID.....	1
15	PAOZZ	5310-00-810-5335	96906	MS15795-507	WASHER, FLAT.....	5
16	PAOZZ	5305-00-984-6195	96906	MS35206-247	SCREW, MACHINE.....	5

END OF FIGURE

